

# PROCESS INTEGRATION

A **SYSTEMATIC** APPROACH FOR THE **OPTIMISATION** OF INDUSTRIAL PROCESSES RECOGNIZED FOR OVER 20 YEARS FOR ITS ABILITY TO...

- Reduce energy consumption by 10 to 30%
- Reduce greenhouse gas (GHG) emissions
- Reduce water usage and effluent production
- Increase profitability
- Increase production capacity at minimal capital cost



Natural Resources  
Canada

Ressources naturelles  
Canada

Canada



## THE APPROACH

Even the most mature and efficient industrial processes may consume between 10 and 20% more energy than necessary. Process Integration (PI) is a powerful analytical method for identifying and selecting concrete technical solutions to correct these inefficiencies and provide an optimum manufacturing solution.

This approach is broadly applicable to a wide variety of industrial processes (Figures 1 and 2) and takes into account the characteristics specific to each plant, balancing production, economic or environmental constraints, product quality and controllability.

## ANOTHER STEP TOWARD EFFICIENCY

During a PI study, a comprehensive and systematic analysis of an industrial process as a whole is performed, rather than solely considering individual items or energy systems independently, in order to determine the best strategies for an efficient use of energy and resources. By taking into account all elements of a process or plant and their interactions, the consumption of energy, water, hydrogen, raw materials as well as operating costs, GHG emissions and other environmental impacts are reduced. PI therefore goes much further than traditional audits, which generally optimise an industrial process by considering each of its individual unit operation separately.

## PINCH ANALYSIS

Over the last twenty years, Process Integration methods have been developed and used with success in most industrial sectors, for both continuous and batch processes. Among these methods, Pinch Analysis, originally developed for the analysis and optimisation of heat exchanger networks and then adapted to optimise water and hydrogen networks, is the most widely used. This is due to the simplicity of its underlying concepts and, especially, to the spectacular results it has obtained in numerous projects worldwide.

## A PI STUDY: A COLLABORATION BETWEEN...

- Plant personnel;
- Engineering firms;
- Process Integration specialists.

## THIS IS BASED ON A 4 STEPS APPROACH:

- Data acquisition and process simulation;
- Energy and mass balance analysis;
- Application of PI techniques (a PI software may be required);
- Technical and economic evaluation of selected projects.

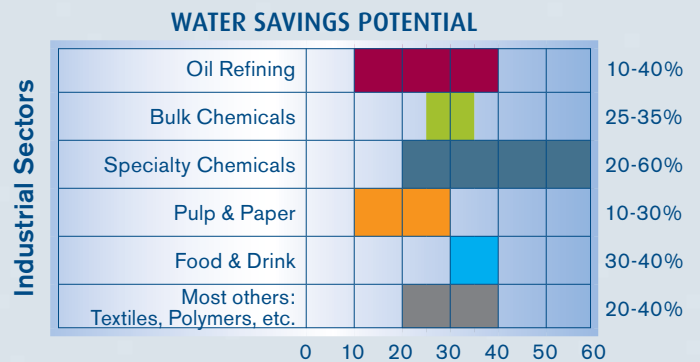
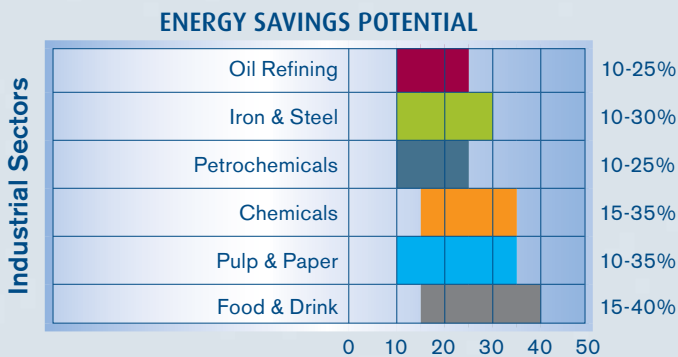

Figure 1 Potential for reduction of energy consumption through PI techniques

Figure 2 Potential for reduction of water consumption through PI techniques

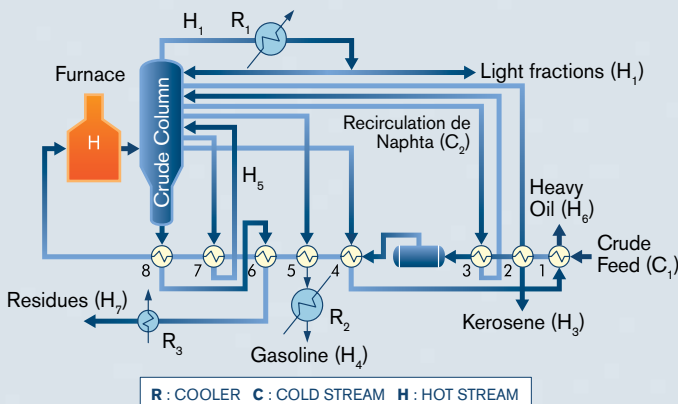

Figure 3 A refinery's crude oil preheating unit before optimisation (existing basic configuration)

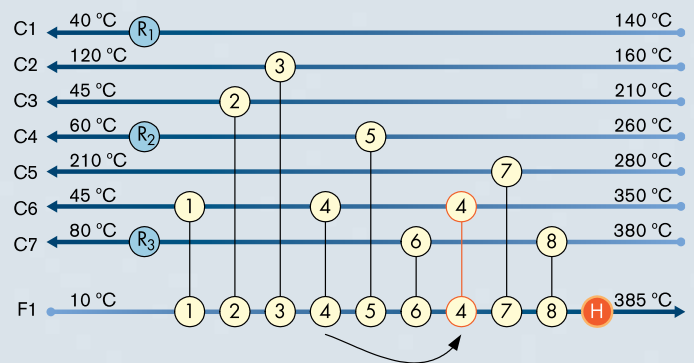

Figure 4 Heat exchanger network for the unit shown in Figure 3. Pinch analysis allows the unit's energy consumption to be reduced by 4.5% by simply optimising the location of heat exchanger n°4 (Source: UMIST)





## PROCESS INTEGRATION IN PRACTICE

A PI study can pinpoint areas where energy, water and hydrogen savings are possible and recommend configuration or processing steps that are technically and economically viable:

- Heat recovery within the process;
- Water re-use and reduction of effluent volume;
- Utility systems optimisation and cogeneration opportunities;
- Debottlenecking of production, utility systems or treatment equipment.

## SERVING CANADIAN INDUSTRY

*CanmetENERGY's Industrial Systems Optimisation Group in Varennes* seeks to expand the use of Process Integration within Canadian industry. We serve Canadian industrial sectors by means of:

- Research and development activities to respond to Canadian industrial issues;
- Promotion of Process Integration benefits;
- Demonstration through industrial projects carried out in close partnership with plants, consulting engineering firms;
- Transfer of expertise.

### CAN YOUR PLANT BENEFIT FROM THE USE OF PI?

To find out, contact one of our specialists

Email: [int-proc@nrcan.gc.ca](mailto:int-proc@nrcan.gc.ca)

Phone: (450) 652-4621



CanmetENERGY in Varennes

1615, Lionel-Boulet Blvd., P.O. Box 4800, Varennes, Quebec, J3X 1S6, Canada

Phone: (450) 652-4621 | Fax: (450) 652-0999 | Web Site: <http://canmetenergy.nrcan.gc.ca>

© Her Majesty the Queen in Right of Canada, 2012

Cat. No.: M154-57/2009E-PDF

ISBN: 978-1-100-19802-6